

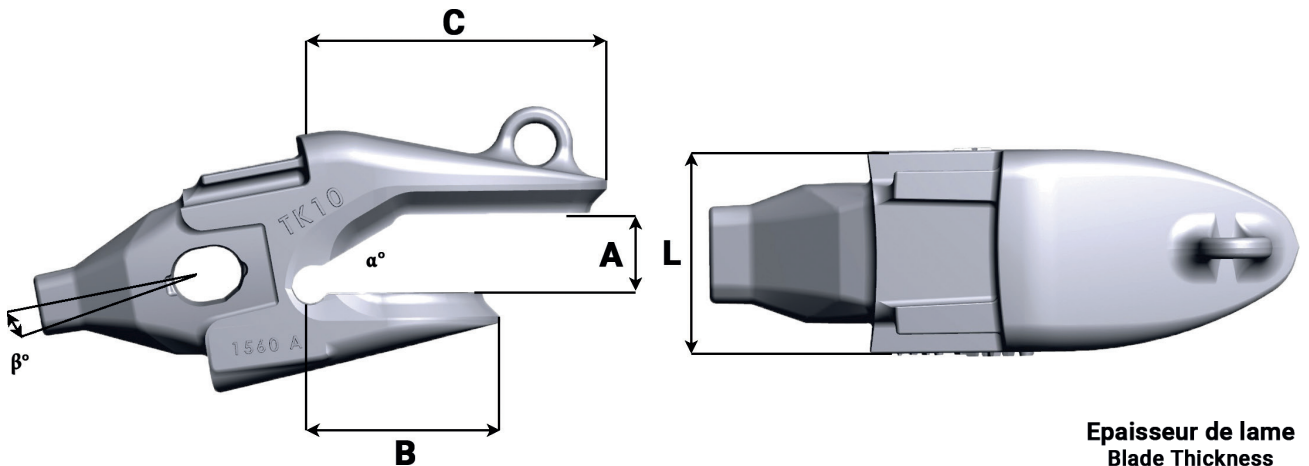

Bucket equipment
for quarrying & mining

TKN10 1560-A10°



Epaisseur de lame
Blade Thickness
60mm / 2.36 in

Référence Part number	Poids Weight Kg/Lbs	A mm/in	B mm/in	C mm/in	L mm/in	α°	β°
TKN10 1560 A10°	31 68.34	62 2.44	137 5.39	240 9.45	150 5.86	30°	10°

